

EC290 (9-Pin)



Description:

NAMCO nuclear connectors, designed for fast easy disconnect-connect operation, dramatically reduce the exposure of personnel to radiation. They maintain the sealed integrity of limit switches and other devices such as solenoid valves, transmitters, etc. by eliminating the need to disassemble and rewire the switches during required maintenance.

All units have a minimum life of 10 years under intense radiation and combine the following product features.

Features:

- Qualified to IEEE Standards 344-1975, 323-1974, and 382-1972.
- Manufactured to a quality assurance program designed to meet the requirements of 10CFR50 Appendix B, and ANSI N45.2, as applicable.

Nuclear Qualified Products

9 Pin Receptacle/Plug-In Quick Connector Systems

Tested and Qualified for Containment Areas
and Other Harsh Environments

- Connector keyed for quick positive one-way connection.
- Bayonet style connection, positive visual locking indicator.
- Radiation-resistant elastomer materials.
- Flexible wire to eliminate kinking and fatigue failure.
- Leakproof to DBE environments including LOCA and HELB conditions — e.g., steam, vapors, pressures up to 80 PSIG and chemical sprays.
- Nine wired pins: Eight leads plus ground wire for EA740/EA180/EA170 Series.
- Cable lengths available from 20 feet.
- Seismic and vibration resistant.

EC290-19001 Receptacle Dimensional Data

Male Receptacle Assemblies may be ordered separately. Please order part number EC290-19001.

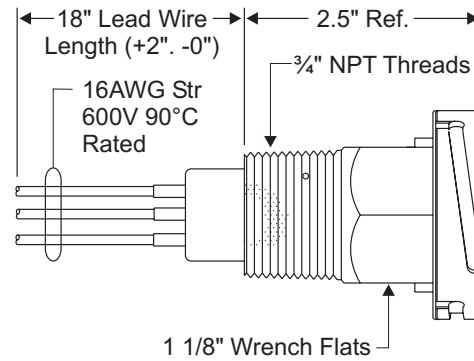

EC290-29xxx Cable Features

600V/90°C rated 9 conductor 16 AWG stranded nuclear grade cable has excellent resistance to radiation, heat, mechanical abuse, flame, weathering, most oils, acids and alkalis.

Cable meet requirements of IEEE Std. 383" type test of Class IE electrical cables.

Plug-In Cable

Cable lengths for the Plug-In Cable Assemblies should be ordered with specific cable lengths between 20 and 100 feet lengths as follows:

Plug-In Cables	
Length	EC290-
20 Ft.	29020
25 Ft.	29025
30 Ft.	29030
35 Ft.	29035
50 Ft.	29050
100 Ft.	29100

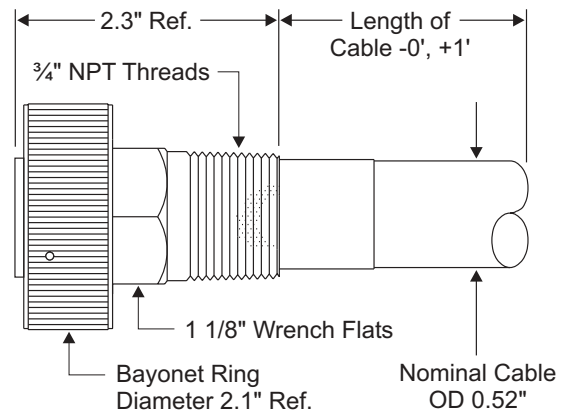

Receptacle Side

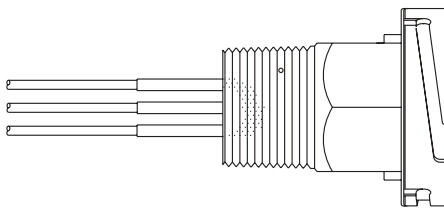

FRONT VIEW
PIN SIDE

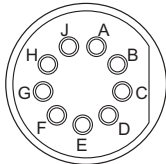

Plug Side

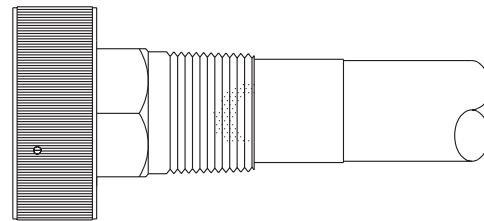

FRONT VIEW
PLUG

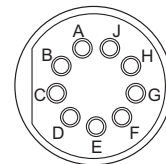

Qualification test report QTR-500 documenting Namco's testing of receptacle connector and cable is available.

